

MECHANICAL ENGINEERING-ME



GATE / PSUs

STUDY MATERIAL
MACHINE DESIGN



eii ENGINEERS
INSTITUTE OF INDIA



MECHANICAL ENGINEERING
GATE & PSUs

STUDY MATERIAL

MACHINES DESIGN

CONTENT

1. MACHINE DESIGN	03-20
2. FLEXIBLE MECHANICAL ELEMENTS	21-30
3. JOURNAL BEARINGS	31-55
4. CLUTCH AND BRAKES	56-77
5. FASTENERS	78-86
6. POWER SCREW	87-105
7. WELDED JOINT	106-113
8. DESIGN OF PERMANENT JOINT	114-120
9. COUPLINGS	121-131
10. GEAR	132-148
11. SHAFT	149-158

CHAPTER-1

MACHINE DESIGN

Engineering: Engineering is the art and science by which the properties of matter and the sources of power in nature are made useful in structures, machines and fabricated parts.

Machine: A machine is a combination of resistant parts so arranged as to cause the forces of nature to produce definite work with constrained motion.

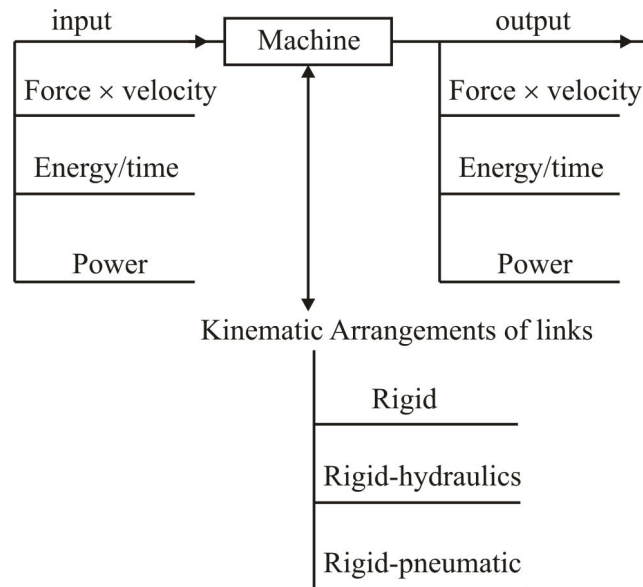

Figure: Representation of Machine.

- **Design:** Design is the process in which scientific principles and the tools of engineering (mathematics, computers, Graphics, English) are used to produce a plan which, when carried out, will satisfy a human need.
- **Machine design:** Machine design is an art and technique of planning the construction of new or improved machine.
- A new machine may be
 - (i) Entirely new in concept performing new types of work
 - (ii) Performing more efficiently and economically, work that can be done by existing machine.
 - (iii) Incorporating some new inventions and some improvements of existing machines.

- Design is characterized by continual change of theory and practice. Knowledge of what has gone before, is important in machine design.

STANDARDISATION:

- A standard is a set of specifications for parts, materials or processes, intended to achieve uniformity, efficiency and a specified quality, it places a limit on the number of items in the specifications so as to provide a reasonable inventory of tooling, size.
- A code is a set of specifications for the analysis, design manufacture and construction of something. The purpose of a code is to achieve a specified degree of safety, efficiency and performance or quality. It is important to observe that safety codes do not imply absolute safety.
- Several organizations and societies have established specifications for standards and safety or design codes, which has legal bindings too in the specified countries.
- Bureau of Indian standards (BIS) is the one functioning in India.

DESIGN FACTORS:

- Design factors are used when there are uncertainties in estimating certain quantities which are critical in design process. The general rule is “be on the safer side”.
- After the design is completed, the actual design factor may change as a result of changes such as rounding up to a standard size for a cross – section or using the off – the – shelf components. With higher ratings instead of employing what is calculated by using the design factor. The factor is then referred to as the factor of safety, n . The factor of safety has the same definition as the design factor, but it generally differs numerically.

Material properties:

- Engineering materials are the materials in the solid state whose properties are technologically useful.
- Requirements of an engineering material are:
 - (i) Component made from it, should perform its function for its specified life,
 - (ii) Must be economically suitable with reference to cost of
 - (a) Material
 - (b) Fabrication
 - (c) Maintenance
 - (d) Machining
 - (iii) To assure reliability of the part, the material should resist
 - (a) Elastic and plastic deformation
 - (b) Fracture
 - (c) Wear
 - (d) Corrosion

TECHNICAL PROPERTIES:

- It consists of various measurable properties for which tests have been run and data are available. It can be classified as:
 - (i) Technological properties. (ii) Physical properties. (iii) Mechanical properties.
- All technological properties concern the manufacturing processes and are relative.
 - Machinability
 - Ease in turning, drilling, reaming etc.
 - Steels 13 s 25 in the cold drawn condition, turning at cutting speed of 54.9m/min with feeds up to 0.1778 mm/rev. using a tungsten steel tool with a proper cutting fluid – 100% machinable.
 - Formability
 - Based on malleability and ductility
 - Alloying elements reduce ductility
 - Cast ability
 - Judged by solidification rate, shrinkage, segregation, gas porosity and hot strength.
 - Weld ability
 - Based on weld quality and ease with which it can be obtained.
 - Depends on oxidation, gas vaporization, solubility, heating and cooling effects.
- Physical properties are relatively constant and are affected only by temperature and do not change with time.
 - (a) Composition (b) Structure (c) Specific weight (d) Thermal conductivity
 - (e) Expandability (f) Corrosion resistance.
- **Mechanical properties:**
 - (a) Modulus of elasticity (b) Elastic limit (c) Yield stress (d) Ultimate strength
 - (e) Resilience (f) Toughness (g) Hardness (h) Endurance limit
- **Resilience:** It is defined as property to store energy and resist shock and impact it is measured by energy stored per unit volume, being stressed to elastic limit.
- **Toughness:** It is defined as property of a material to resist brittle fracture or crack propagation. It is measured stressed to the point of fracture (Charpy impact test).

- **Hardness:** It is defined as property to resist penetration, indentation or abrasion (or plastic deformation). Brinell, Rockwell and Vicker's hardness tests are performed to measure this.
- **Endurance limit:** It is defined as highest alternating stress to which a highly polished material can be subjected, an infinite number of times without failure.

LOADING ON MACHINE ELEMENTS

- Machine parts fail when the stresses induced by external forces exceed their strength. The external load cause internal stress in the elements and the component size depends on the stresses developed. Loading may be due to:
 - (a) The energy transmitted by a machine element.
 - (b) Dead weight
 - (c) Inertial forces
 - (d) Thermal loading.
 - (e) Frictional forces.
- Load may be classified as:
 - (a) Static load – load does not change in magnitude and direction and normally increases gradually to a steady value.
 - (b) Dynamic load – load may change in magnitude for example, traffic of varying weight passing a bridge.

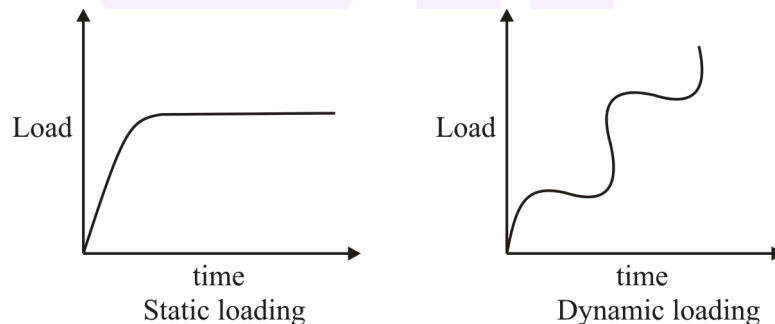

STRESS CONCENTRATION:

- The increase in localized stress due to an abrupt change in cross – section called a discontinuity or a stress raiser. The regions in which they occur are called areas of stress concentration.
- A theoretical or geometric stress – concentration factor k_t or k_{ts} is used to relate the actual maximum stress at the discontinuity to the nominal stress. The factors are defined by the equations

$$k_t = \frac{\sigma_{\max}}{\sigma_0}, \quad k_{ts} = \frac{\tau_{\max}}{\tau_0}.$$

Where k_t is used for normal stresses and k_{ts} for shear stresses. The subscript 't' in k_t means that this stress – concentration factor depends for its value only on the geometry of the part.

- In ductile ($\epsilon_f \geq 0.05$) materials, the stress-concentration factor is not usually applied to predict the critical stress, because strengthening effect. In brittle material ($\epsilon_f < 0.05$). The geometric stress concentration factor k_t is applied to the nominal stress before comparing it with strength.
- Stress in the fibers nearest to the discontinuity is increases most.
- Stress concentration due to discontinuity occurs for any kind of loading viz. a direct load, bending or torsion.
- The maximum stress at the discontinuity are.

- $S_1 = \left(\frac{P}{A}\right)k_t$, for direct load.

- $S_1 = \left(\frac{MC}{I}\right)k_t$, fro bending.

- $S_1 = \left(\frac{TC}{J}\right)k_t$, for torsion.

A, J, I are based on the net section.

- K Depends only on the geometric form of the discontinuity sometimes, it is also referred to as the form – stress factor.
- Due to local yielding of ductile material at the point of excessive stress, the effective stress concentration factor, k used in design, is always lower than the corresponding theoretical stress factor k_t .
- In design, k_t is used with extremely brittle materials.
- Stress concentration in tension members may be represented by lines indicating the direction of the principal stresses.
- In the figures, at both ends of the plate, the lines are parallel indicating uniform stresses; at the right end, they are closer together, indicating higher stresses.

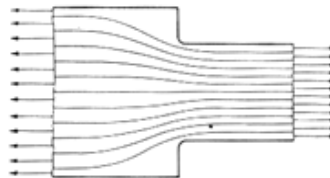

- These lines are usually called force flow lines.
- Force flow lines are quite useful in visualizing stress concentration created by discontinuities, created by discontinuities, and in taking remedial steps to reduce stress concentration.
- The force flow lines indicate that the stress concentration induced by elliptical holes is lower in figure (b).

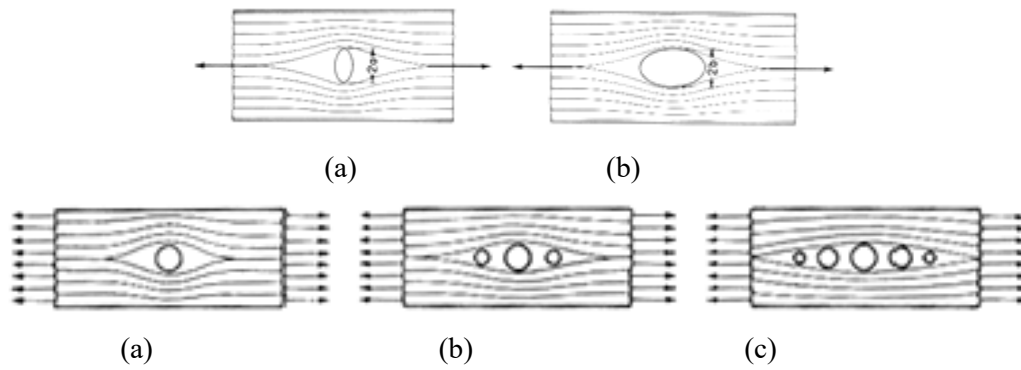

Figure: Reduction of stress concentration in tension

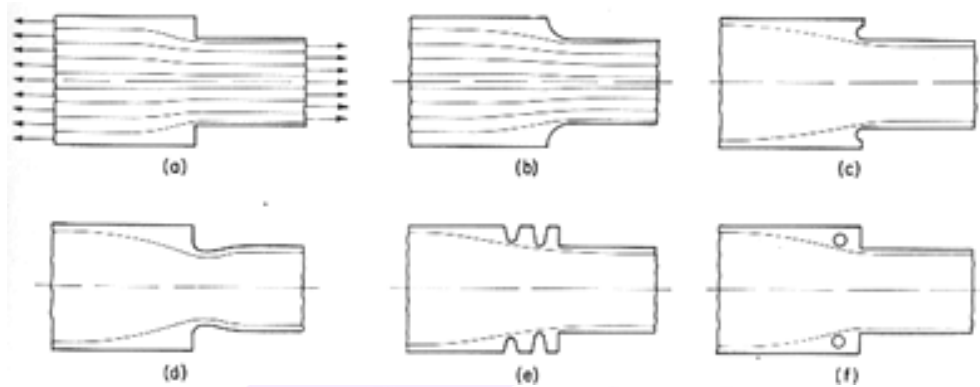

Figure: Reduction of stress concentration in tension

➤ Estimation of stress concentration factors:

- Free round holes:
Stress distribution in a plate of infinite width containing a round hole.
For an elliptical hole, the maximum stress is,

$$\sigma_{\max} = \sigma_0 \left(1 + \frac{2a}{b} \right)$$

Where 'a' and 'b' are semi-major and semi-minor axes of the ellipse.

Transverse stress $S_2 = N S_0$.

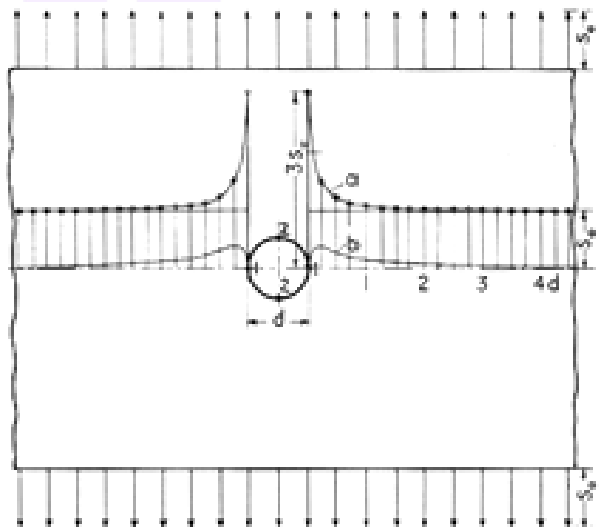

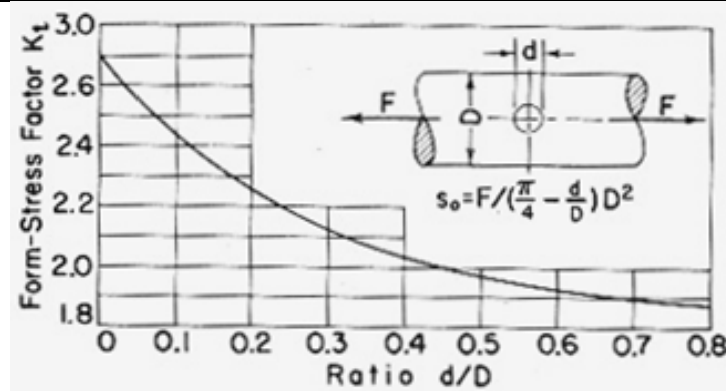
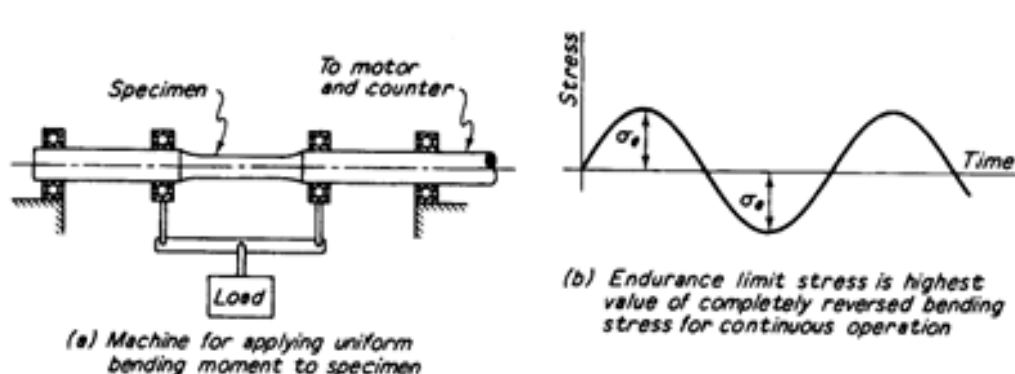

Figure: Form stress factor due to through hole in shaft loaded in tension

FATIGUE FAILURE:

- Of ten machine members are found to have failed under the action of repeated or fluctuating stresses. Yet the most careful analysis reveals that the actual maximum stresses were well below the ultimate strength of the material and quite frequently even below the yield strength. The most distinguishing characteristics of these failure is that the stresses have been repeated a very large number of time. Hence, the failure is called a fatigue failure.
- Many static failures give visible warning in advance. But a fatigue failure gives no warning! It is sudden and total, and hence dangerous.
- A fatigue failure has an appearance similar to a brittle fracture, as the fracture surfaces are flat and perpendicular to the stress axis with the absence of necking. The fracture features of a fatigue failure, however, are quite different from a static brittle fracture arising from three stages of development.
- Fatigue failure is due to crack formation and propagation. A fatigue crack will typically initiate at a discontinuity in the material where the cyclic stress is a maximum.
- Rotating beam fatigue test:



The loading is such that there is a constant bending moment over the specimen length and the bending stress is greatest at the center where the section is smallest. The arrangement gives pure bending and avoids transverse shear since bending moment is constant over the length. Large numbers of tests with varying bending loads are carried out to find the number of cycles to fail. A typical plot of reversed stress (s) against number of cycles to fail (w) is shown in figure. The zone below 10^3 and 10^6

cycles is high cycle fatigue with finite life and beyond 10^6 cycle. The zone is considered to be high cycle fatigue with infinite life.

For non – ferrous metals, there is no knee in the curve as shown in figure, indicating that there is no specified transition from finite to infinite life.

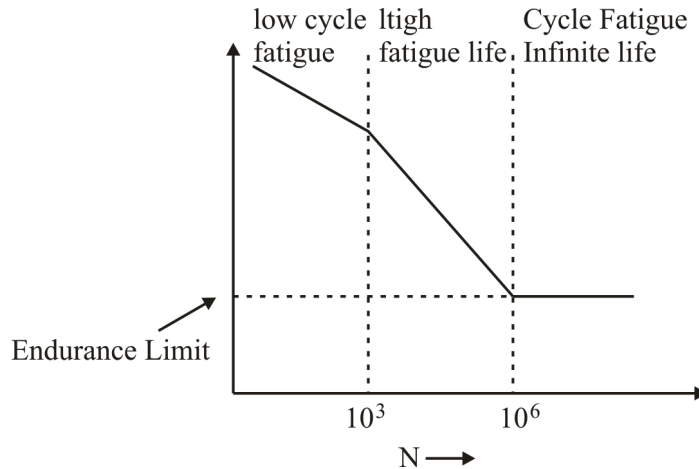

Figure: A schematic plot of reversed stress (S) against number of cycles to fail (N) for steel

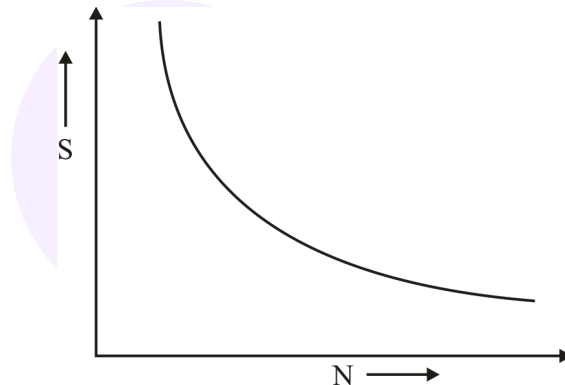

Figure: A schematic plot of reversed stress (S) against number of cycles to fail (N) for non-metals, showing the absence of knee in the plot.

➤ A schematic plot of endurance limit for different materials against the ultimate tensile strength is shown in figure. The points lie within a narrow band and the following data is useful:

Steel endurance limit ~ 35-60% UTS.

Cast iron endurance limit ~ 23.63% UTS.

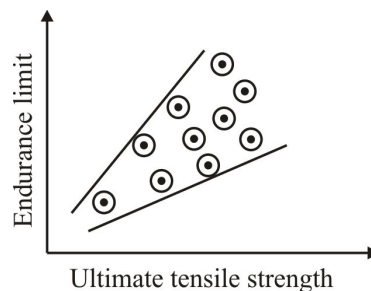

Figure: A schematic representation of the limits of variation of endurance limit with ultimate tensile strength

- The endurance limits are obtained from standard rotating beam experiments carried out under certain specific conditions, they need be corrected using a number of factors.

In general, the modified endurance limit σ_e' is given by

$$\sigma_e' = \sigma_e \frac{C_1 C_2 C_3 C_4 C_5}{K_F}$$

- C_1 is the size factors and the values may roughly be taken as

$$C_1 = 1 \quad d \leq 7.6 \text{ mm}$$

$$= 0.85 \quad 7.6 \leq d \leq 50 \text{ mm.}$$

$$= 0.75 \quad d \geq 50 \text{ mm.}$$

For larger size, $C_1 = 0.6$

This data applies mainly to cylindrical steel parts.

- C_2 is the loading factor and the values are given as

$$C_2 = 1 \text{ for reversed bending load.}$$

$$= 0.85 \text{ for reversed axial loading for steel parts.}$$

$$= 0.78 \text{ for reversed torsion loading for steel parts.}$$

- C_3 is the surface factor and since the rotating beam specimen is given a mirror polish, the factor is used to suit the condition of a machine part. Since machining process, rolling and forging contribute to the surface quality, the plots of C_3 versus tensile strength or Brinnel hardness number for different production process, in figure, is useful in selecting the value of C_3

Published Books

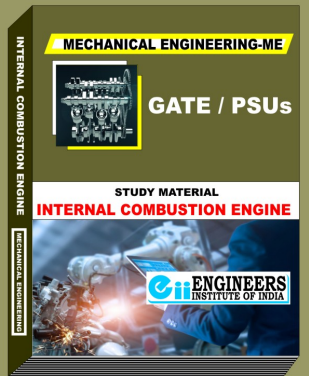
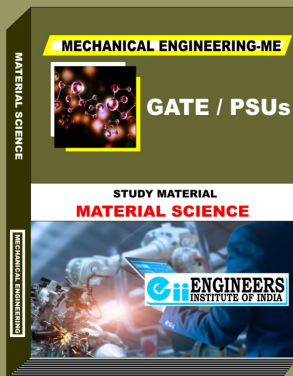
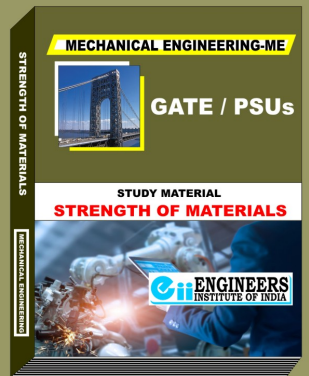
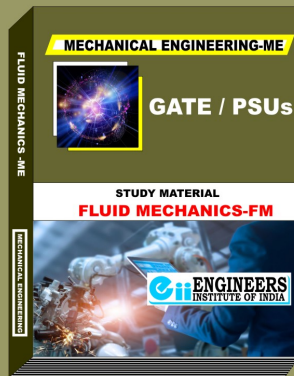
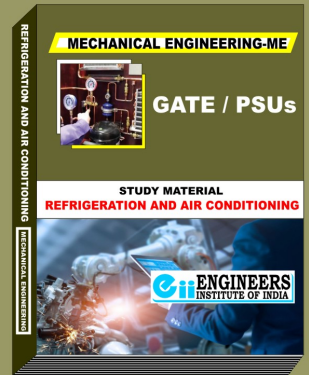
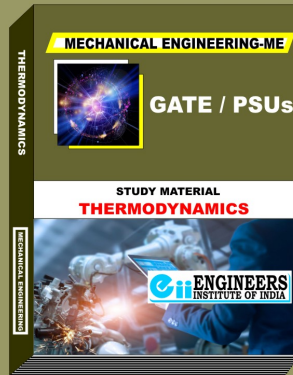

Classroom Batches

Online Classes

Postal Course Classes

Online Test Series

Office: 58B, Kalu Sarai Near Hauz Khas Metro Station New Delhi-16

Helpline: 9990657855 , 9990357855

www.engineersinstitute.com